



triton
Precision Power Tools

BORN IN AUSTRALIA

Est. 1976

Engineered Precision
2017



Brand Story



Precision has been at the very heart of Triton's philosophy since 1976, when the first Workcentre was produced. Born in Australia, Triton tools continue to be built with this philosophy at the forefront of every project. From award-winning routers and laser-guided circular saws, to the industry-renowned Superjaws and the new innovative TWX7 Workcentre, you can rely on Triton for tools that provide an accurate, quality finish every time.



Contents

Workcentre Systems.....	4
Workcentre Basic Execution.....	6
Workcentre Accessories.....	8
Router Table Module.....	10-11
Contractor Saw Module.....	12-13
Project Saw Module.....	14-15
Precision Routing.....	16-19
Powerful Cutting.....	20-23
Straight Cutting.....	24-25
Unbeatable Sanding.....	26-29
Accurate Jointing.....	30-31
Innovative Planing.....	32-35
Bench Top.....	36-40
Work Support.....	41-44
SuperJaws Clamping System.....	41
Multi-Stand.....	43
Woodrack Storage System.....	44
Series 2000.....	45-46
Router Table System.....	45
Router Stand.....	46
Router Table Accessories.....	46
Workcentre Accessories.....	47



“ The benchmark in
precision power tools
for 40 years ”

Workcentre Systems

The new TWX7 brings the precision and convenience of a Triton Workcentre to a new generation. Constructed using lightweight yet robust extruded aluminium sections, supporting innovative low friction work surfaces, it remains an ideal solution for the enthusiast woodworker. Moreover the TWX7 is now both a highly capable and mobile multi-purpose workshop for professional site use. Precision and accuracy are assured, coupled with high mobility, making the Triton WorkCentre WX7 ideally suited for site trades such as kitchen or shop fitters and other finishing operations, where access to workshop facilities and accuracy ensures the highest quality results.



Easy fit modules
for quick configuration



Lightweight aluminium frame
folds down for portability and storage



Mains isolator switch fitted
for use with power tools



Work Centre Table
Sturdy Construction



“

**Power tool solution
for woodworkers**

”

Workcentre Basic Execution

TWX7 LB

The TWX7 builds on the legacy of previous Triton Workcentres, with their reputation for precision, ease of use and versatility. Using the latest advanced materials technology and a new fast-change modular approach, this new system is ideal for the workshop enthusiast as well as the on-site carpentry professional.

Lightweight and robust, extruded aluminium sections support an innovative low-friction work surface and clamping table module. Dual extruded T-rails, for attaching accessories, run the full length of the table.

Fast switch-out modules transform the Workcentre between modes from bare table to router table, table saw or project saw.

Optional side and outfeed supports extend the frame for larger workpieces, whilst a rugged transit kit and folding frame bring a new level of portability to this workshop classic.

Power Switch with 'Knee Off' Quick-Stop Panel

for operator safety

Table Top Height 900mm (3ft)

optimised for safe & comfortable working



Fold and Lock Legs

for easy storage & transport

Maximum Static Working Load 150kg (330lbs)

for the most complex projects

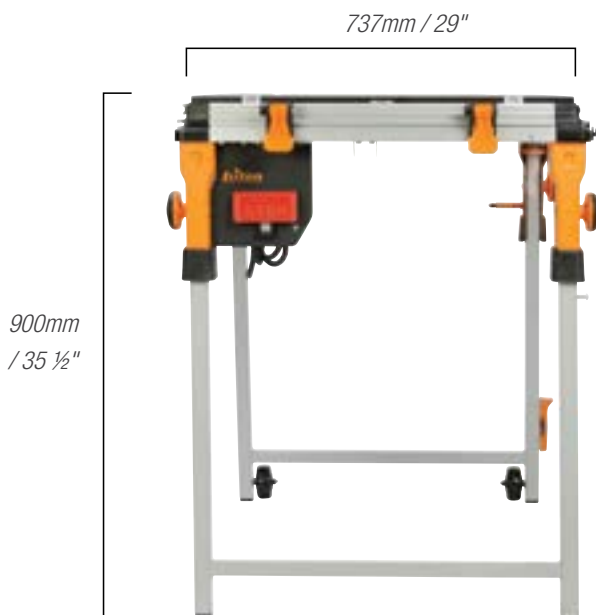

Low Friction Micro Dot Surface
on frame-feed areas

Dual T-Track Rail

for accessory mounting

**Fast-Change Latches
Lock & Centre the Module**

for easy swap-out between
operating modes

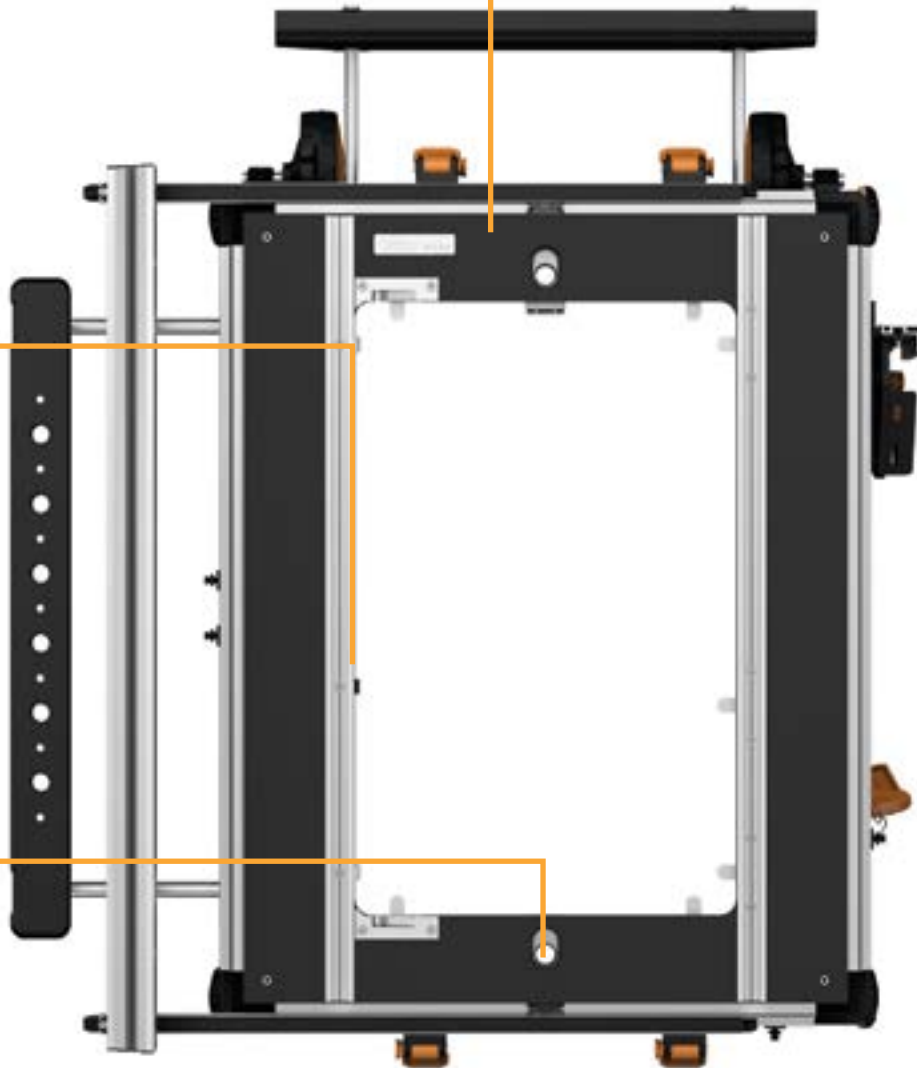

“This is up there with the top-end German workbenches. There is no compromise here – I can’t think of any features they haven’t covered.”

Roger Bisby, Professional Builder Magazine

Technical Specification

Dimensions (Standing)	1036 x 737 x 900 mm (40¾" x 29" x 35½")
Dimensions (Folded)	995 x 737 x 317 mm (39¼" x 29" x 12½")
Module Insert Dimensions	660 x 410 x 50mm (26" x 16¼" x 2")
Max Load Capacity	150kg / 330lbs
Weight (Chassis Only)	23.2kg / 51lbs

Item	Part No.	Description
804680	TRI-TWX7LB	Workcentre Series Lite Bare Table

Disclaimer: Every effort has been made to publish the correct details in this brochure. No responsibility will be taken for errors, omissions or changes in product specifications.

Workcentre Accessories

Taking the Workcentre to the next level, these attachments provide an all-important combination of extra support and functionality so users can focus on specific projects. Each accessory is specially designed for use with the Triton WX7 for controlled, precise operation and accurate results.

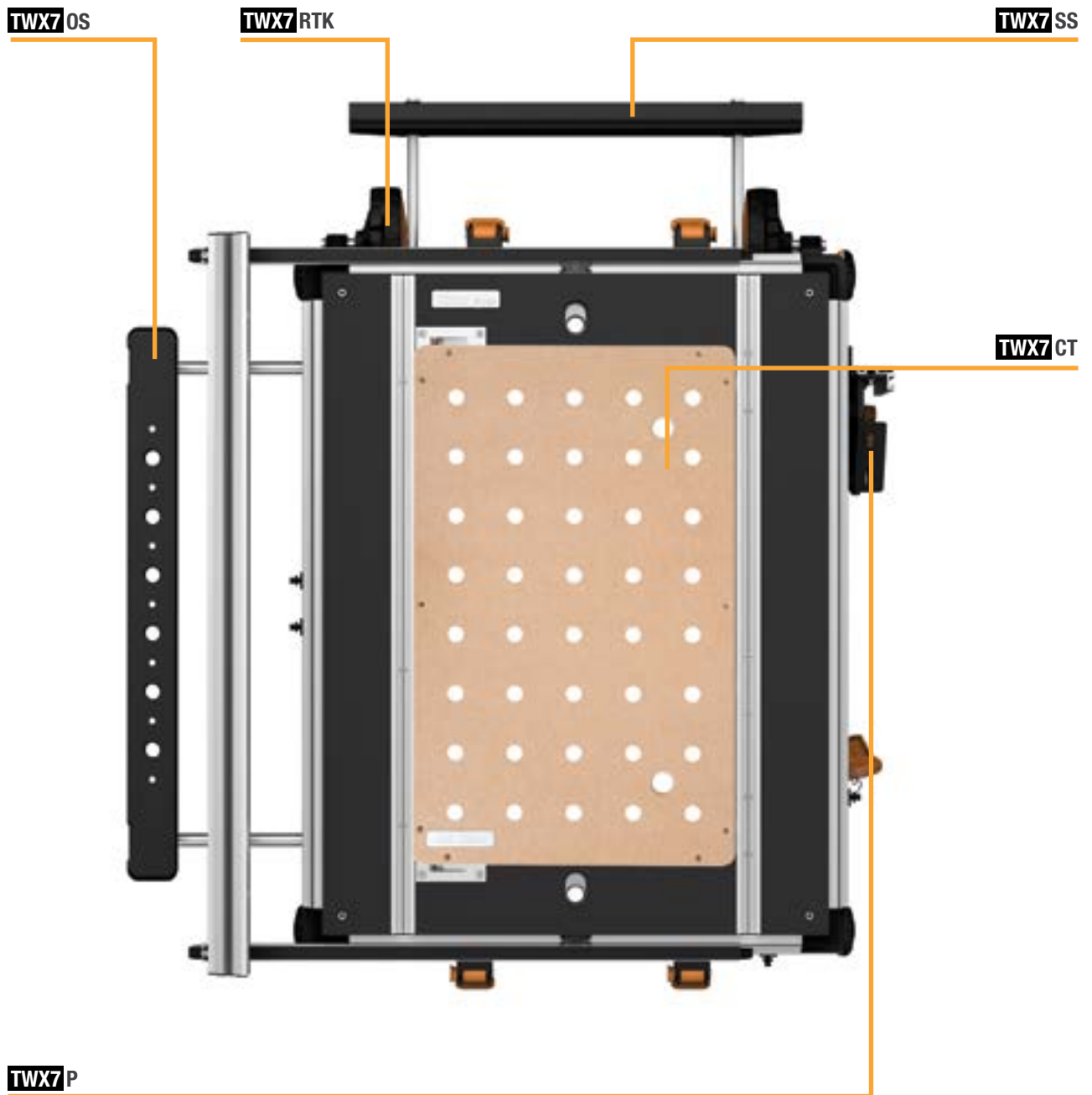

TWX7 OS

Outfeed Support



Ideal for performing rip cuts or dealing with large projects, the Outfeed Support bracket provides an adjustable reach which provides support to the workpiece.

- Chrome-plated extension bars prevent corrosion
- Outfeed support bracket supports longer workpieces
- Adjustable extension fits any workpiece to 670mm from the centre

Item	Part No.	Description
804689	TRI-TWX7OS	Outfeed Support for TWX7 Workcentre

TWX7 SS

Side Support



Provides an adjustable reach which supports the workpiece. Particularly useful when dealing with large projects.

- Chrome-plated extension bars prevent corrosion
- Side support bracket supports wider workpieces
- Adjustable extension fits any workpiece up to 600mm from the centre line

Item	Part No.	Description
804688	TRI-TWX7SS	Side Support for TWX7 Workcentre

TWX7 RTK

Rugged Transit Kit



Ideal for transporting the workcentre across uneven terrain, the rugged transit kit attaches to the workcentre chassis, and is pivot mounted for user comfort. The large diameter handle mount ensures force is distributed evenly during transit.

- Large diameter wheels suitable for transit across uneven terrain
- Grooved tread pattern provides traction on a multitude of terrains
- Wheel covers protect internal components

Item	Part No.	Description
804690	TRI-TWX7RTK	Rugged Transit Kit for TWX7 Workcentre

TWX7 P

Protractor Gauge



The protractor gauge provides unparalleled levels of precision when performing angled mitre cuts with the workcentre TWX7.

- Acts as angular support for complex workpiece shapes and sizes
- Fits into Workcentre T-slot for easy installation
- Adjustable main fence and fixed 45° fences

Item	Part No.	Description
805005	TRI-TWX7P	Protractor to suit TWX7 Work Centre

DCA 300

Dust Collector

Prevents sawdust filling up or clogging your vacuum cleaner. 20Ltr / 5 US gal capacity.



Item	Part No.	Description
801210	TRI-DCA300	20Ltr Dust Collection Bucket

TRA001 MOF001 JOF001

Routers

Designed and engineered to 'quick fit' to the Router Module, with added features to enhance its operation and accuracy.



TWX7 CT

Clamping Table (Gluing Table)

MDF Clamping table with 20mm holes. Table size 850 x 650mm (33½ x 25½"), provides plenty of space to support project work.

Item	Part No.	Description
805003	TRI-TWX7CT	Clamping table module to suit TWX7 work centre
805004	TRI-TWX7CTFK	Clamping table fitting kit to suit TWX7 work centre



Router Table Module

TWX7 RT001

The router table module for the TWX7 Workcentre has a micro dot laminate surface, which produces minimal friction on the workpiece.

This allows it to move freely against the integral fence, and when working in freehand mode. Accuracy is assured with cruciform depth-adjustable extending face plates and micro adjusters, and safety is enhanced with the provision of both vertical and horizontal featherboards (supplied).

With a Triton Router fitted, precise adjustment is achieved with a through-the-table height winder. Close-fitting clear guards protect the operator.

The guard dust extraction point is positioned close to the cutter for maximum efficiency, working in combination with the router's own dust extraction connector under the work surface for dual extraction.

From simple edge-planing to robust panel-raising, this expert level mobile table is equally at home in the workshop or on site.

Cruciform Depth-Adjustable Fence

for accurate edge planing



Height-Adjustable Bit Guard with Dust Extraction Point

maintains a clear, safe view of the workpiece

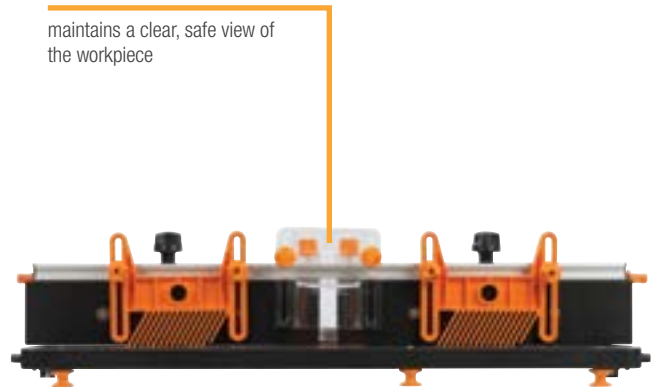

Compatible with

TRA001 – 2400W Router

MOF001 – 1400W Router

JOF001 – 1010W Router

TWX7 – Workcentre



TRA001 **MOF001** **JOF001**

Routers

Designed and engineered to 'quick fit' to the Router Module, with added features to enhance its operation and accuracy.

Low-Friction Microdot Work Surface

for improved control of feed material

Micro-Adjusting Fence

with +25-125mm (1"x5") opening

Through the Table Height Winder Adjustment

for above table cutter change & fine adjustment

Dust Extraction Connector

for both high pressure & low pressure dust extraction systems

Horizontal & Vertical Feather Boards

secure the workpiece for safe, smooth cutting

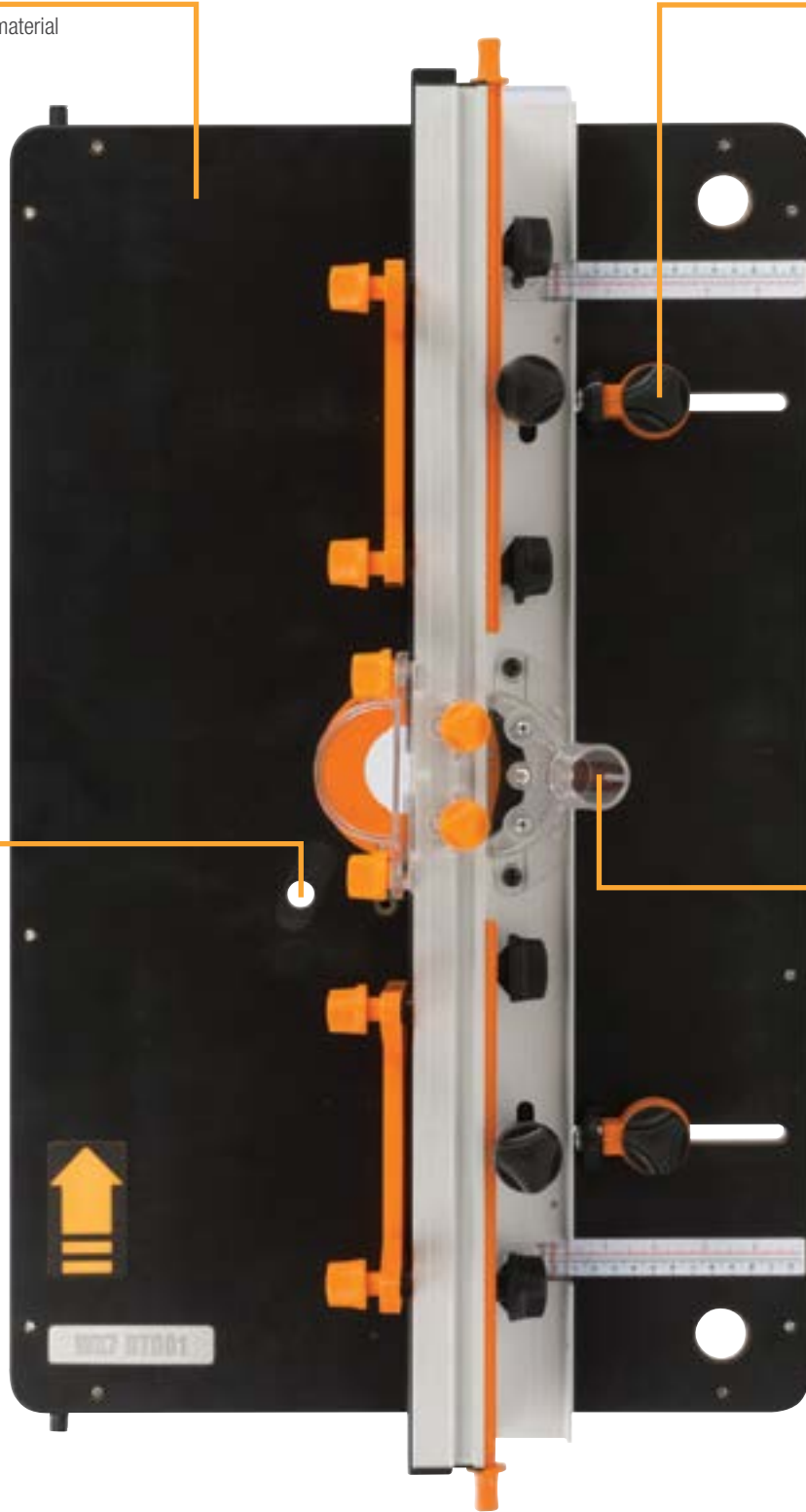

Technical Specification

Module Size	660 x 410mm / 26 ³ / ₄ " x 16 ⁵ / ₈ "
Extruded Fence Size	680 x 85mm / 26 ³ / ₄ " x 3 ³ / ₈ "
Extruded Fence Thickness	21.4mm / 0 ⁷ / ₃₂ "
MDF Fence Face Size (x2)	340 x 75mm / 13 ²⁵ / ₆₄ " x 3"
MAX MDF Fence Face Opening	90mm (3 ¹ / ₂ "
Fence Adjustable Position	+25/-125mm (+1/-5")

Fence Micro Adjusters	1mm (one full revolution)
Weight	9.8kg / 22lbs
Spacer Bar Settings	0.5, 1.0, 1.5, 2.0mm
Guard Height	0-76mm / 0-3"
Featherboard Stack Height	1: 9.5mm / ³ / ₄ " 2: 15mm / ⁹ / ₁₆ " 3: 44mm / 1 ³ / ₄ " 4: 50mm / 2"
Maximum Throat Plate Router Bit Diameter (Dmax)	Large: 50mm / 2" Medium: 40mm / ¹⁹ / ₁₆ " Small: 20mm / ¹³ / ₁₆ "
Dust Extraction Fitting	High Pressure: 31.75mm / 1 ¹ / ₄ " Low Pressure: 62.5mm / 2 ¹ / ₂ "
Weight	9.8kg / 22lbs

Item	Part No.	Description
804685	TRI-TWX7RT001	Router Table Module for TWX7 Workcentre

Disclaimer: Every effort has been made to publish the correct details in this brochure. No responsibility will be taken for errors, omissions or changes in product specifications.

Contractor Saw Table Module

TWX7 CS001

At the heart of every workshop is a table saw. This has always been the starting point for the Triton Workcentre concept.

The contractor saw module brings a level of advanced precision with increased safety in a fast switch-out module for the TWX7 Workcentre.

This 'no compromise' contractor saw module provides a powerful and versatile table saw function for the Triton WX7 Workcentre.

With a cast aluminium table and a highly accurate dual locking point, fence precision cuts can be assured. The blade tilts to 45°, so bevel cuts can be made safely and easily, even with the largest sheet materials.

Enclosed guarding above and below the table and an effective anti-kickback mechanism ensures operator safety and aids efficient dust extraction.

Riving Knife

prevents material from jamming



Blade Height & Angle Adjustment

easy to use & accurate to achieve any cut

Enclosed Guard with Above-The-Table Dust Extraction Point

for a cleaner, safer working environment



Below-the-Table Dust Extraction Point

for a cleaner, safer working environment



Durable Aluminium Table Surface

low friction & hard wearing

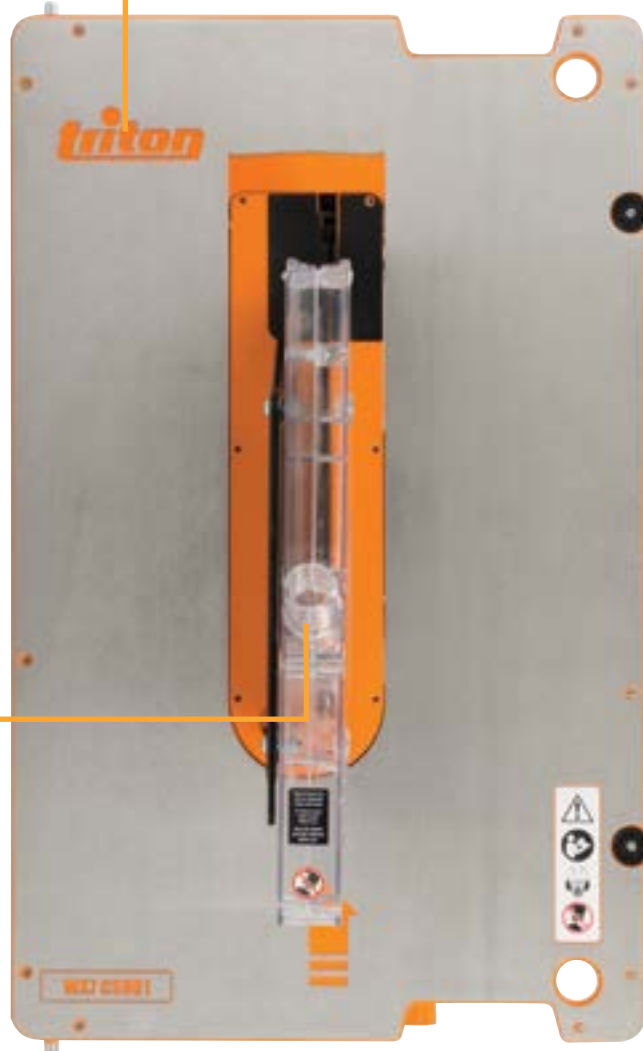

Clear Cutting Guard with Integral Dust Extraction

for operator safety and efficient dust removal



Dualpoint Locking Rip Fence with 620mm (2ft) Capacity

(either side of the table)

Technical Specification	
Power	1800W
No Load Speed	4500rpm
Blade Diameter	254mm / 10"
Bore Diameter	30mm / 1 1/8"
Blade Teeth	40 TCT
Bevel Range	0° - 45°

Max Angle of Cut	45° - 59.5mm / 45° - 2-1/4" 90° - 86mm / 90° - 3-1/2"
Max Rip Cut Capacity	775mm / 30 1/2"
Module Size	660 x 410mm / 26 3/4" x 16 1/8"
Table with Side Extension	+600mm / + 23 1/2"
Table with Outfeed Extension	+670mm / + 26 1/2"
Max Workpiece Size L x W	851x775mm
Dust Extraction Port Size	32.6mm / 1 3/8"
Weight	15kg / 11lbs

Item	Part No.	Description
804686	TRI-TWX7CS001	Contractor Saw Module for TWX7 Workcentre

Disclaimer: Every effort has been made to publish the correct details in this brochure. No responsibility will be taken for errors, omissions or changes in product specifications.

Project Saw Module

TWX7 PS001

The majority of table saw work involves smaller components from sheet or strip materials, and the project saw module makes an ideal, very safe alternative to a full-scale table saw.

The project saw module is a professional solution for precision rip and cross cutting and trimming of hard and soft wood as well as laminate flooring, skirting and loft boards.

It can be used independently of the Workcentre in confined spaces, or fixed into the TWX7 platform for a stable surface at the optimum working height.

A die cast mitre and rip fence, together with a quick-release clamp, means you can easily achieve perfect angled cuts. With a fully enclosed blade and excellent dust extraction this is the ideal table saw for smaller projects.

Integral Carry Handle & Cable Storage

for easy portability & storage



Flat Base Feet

for use independently of the workcentre



Compatible with

TWX7 – Workcentre



TWX7

TWX7 Workcentre

Precision contractors saw module designed for use with the Workcentre TWX7, resulting in a full-featured saw table capable of professional results.

Ergonomic Saw Handle

for a sure, safe grip

Dust Port Adaptor

for above table dust extraction systems

Die Cast Mitre & Rip Fence

for accurate, square & angled cuts

Dual Slide Bearing

provides ultra-smooth glide during cross cutting

Locking Pin

fixes cutter for use as a rip saw



Technical Specification

Maximum Depth of Cut	0-22mm / 0- 7/8"
Blade Size	127mm / 5"
Module Width	410mm / 16 1/8"
Module Length	660mm / 26 3/4"
Max Module Depth	24.4mm / 1" approx
Work Surface Thickness	+25/-125mm (+1/-5")
Work Surface Material	Cast Aluminium
Weight	10kg / 22lbs

Item	Part No.	Description
804687	TRI-TWX7PS001	910W Project Saw for TWX7 Workcentre

Disclaimer: Every effort has been made to publish the correct details in this brochure. No responsibility will be taken for errors, omissions or changes in product specifications.

Precision Routing

Triton Routers are quite simply the most versatile tools in the precision woodworker's armoury. Total control over the tool and the workpiece is guaranteed with patented rack and pinion depth adjustment whilst electronic speed management delivers exactly the right level of power to the cutting face. Precision engineered innovation, without compromise on performance or safety.



“ Affordable quality for all users and makers across the world ”

Dual Mode Precision Plunge Router

TRA 001 2400W

Designed by woodworkers for woodworkers, the multi-award winning TRA001 has been the benchmark in professional routers around the world since its release.

One of the most significant features of this machine is its ability to switch from a conventional plunge router to a fixed-base mode router, with rack and pinion height adjustment at the push of a button.

Simple ideas are often the best. The 3-stage, pre-set height adjustment system is a perfect example. It only takes seconds to remove the plunge return spring, which then allows for easy lifting and adjustment of the machine when mounted in a router table.

Safety has also been carefully considered, especially where bit changes are concerned. The automatic spindle lock will only engage when the power switch safety cover is closed, ensuring the tool cannot accidentally be switched on during the bit-changing procedure.



Micro Winder

enables continuous fine depth adjustment through the full plunge range



Soft Start & Variable Speed

provides the perfect speed for all cutter types

Removable Plunge Spring

for easy bit adjustment when table mounted



Single Wrench Bit Change

through the base with the automatic spindle lock



Technical Specification

Power	2400W
Speed	8000 - 21,000rpm Speed Maintenance Under Load
Soft Start	Yes
Electronic Speed Maintenance	Yes
Collet	1/2" & 1/4" (EU: 1/2" & 12mm)
Depth Adjustment	1. Winder Handle Rack and Pinion 2. Micro Winder 3. Conventional 'Free' Plunge
Plunge Range	0 - 68mm / 0 - 2 2/32"
Dust Extraction	Yes
Bit Changes	Through-Base, Single Wrench Action, Auto Shaft Lock
Micro Adjustment	Infinite
Spindle Lock	Auto
Safety Power Switch	Yes
Removable Plunge Spring	Yes
Guide	Extended Baseplate with Adjustable Fence
Weight	6.3kg / 13.4lbs

Included Accessories

Table Height Winder handle & Multi-Function Fence

Item	Part No.	Description
804900	TRI-TRA001	Dual Mode Precision Plunge Router 2400W

Disclaimer: Every effort has been made to publish the correct details in this brochure. No responsibility will be taken for errors, omissions or changes in product specifications.

Dual Mode Precision Plunge Router

MOF 001 1400W

Developed from the multi-award winning TRA001, the MOF001 has won many prestigious awards around the globe since its release.

Quiet, easy to control and simple to adjust, this compact machine is ideal for those looking for a router equally suited for table-mounted and hand-held use.

Soft start allows close control during hand-held use, with even greater control available by fitting the multi-function fence, which is ideal for circle cutting. Variable speed ensures the router will handle a wide variety of bits for exact shaping of material.

For table mounting, quick-fit pins are located in the base, allowing rapid fitment to the mounting plate, so the MOF001 is completely compatible with the TWX7 Router Module, RT001 and RTA300 Router Table Alike.



Router Accessory Kit

- Machined & plated brass guide bushes in 8 popular sizes
- Dust chute for efficient chip extraction beneath the cut
- Compatible with Triton MOF001 & JOF001 Precision Plunge Routers

Machined, chrome-plated brass guide bushes and chrome-plated steel guide plates. Ventilated guide bushes for optimised dust extraction.

Includes 8 guide bushes (OD 5/16", 3/8", 7/16", 1/2", 5/8", 51/64", 3/4" & 30mm), alignment bush (porter cable adaptor), table spacer and 2 x M4 screws.



Technical Specification

Power	1400W
Speed	8000 – 21,000rpm Speed Maintenance Under Load
Soft Start	Yes
Electronic Speed Maintenance	Yes
Collet	1/2" & 1/4" (EU: 1/4" & 8 mm)
Depth Adjustment	1. Winder Handle Rack and Pinion 2. Micro Winder 3. Conventional 'Free' Plunge
Plunge Range	0 – 59mm / 0 – 2 3/16"
Dust Extraction	Yes
Bit Changes	Through-Base, Single Wrench Action, Auto Shaft Lock
Micro Adjustment	Infinite
Spindle Lock	Auto
Safety Power Switch	Yes
Removable Plunge Spring	Yes
Guide	Extended Baseplate with Adjustable Fence
Weight	4.7kg / 10.6lbs

Included Accessories

Table Height Winder handle & Multi-Function Fence

Item	Part No.	Description
804890	TRI-MOF001	Dual Mode Precision Plunge Router 1400W
803129	TRI-TGA250	12 pce Router Accessory Kit

Compact Precision Plunge Router

JOF 001 1010W

Completing Triton's range of award-winning professional routers is the JOF001 Compact Precision Plunge Router.

Light and exceptionally compact in design, the JOF001 is the ideal machine for freehand work.

With automatic spindle lock for one-handed bit changes, and micro winder for continuous fine depth adjustment through the full plunge range, this compact precision router incorporates many of the award-winning features of its bigger brothers - TRA001 and MOF001.

Quick-fit pins enable fast fitment and removal from both the TWX7 Router Module and the Triton RTA300 Precision Router Table and the above-the-table height winder allow quick and easy fine-tuning of depth setting when the router is table-mounted.

Ideal for hand-held use, the soft start enables complete control whilst the machine powers up, and variable speed ensures the perfect speed is available for all cutter types.



Router Accessory Kit

- Machined & plated brass guide bushes in 8 popular sizes
- Dust chute for efficient chip extraction beneath the cut
- Compatible with Triton MOF001 & JOF001 Precision Plunge Routers

Machined, chrome-plated brass guide bushes and chrome-plated steel guide plates. Ventilated guide bushes for optimised dust extraction.

Includes 8 guide bushes (OD 5/16", 3/8", 7/16", 1/2", 5/8", 51/64", 3/4" & 30mm), alignment bush (porter cable adaptor), table spacer and 2 x M4 screws.



Technical Specification

Power	1010W
Speed	8000 - 21,000rpm Speed Maintenance Under Load
Soft Start	Yes
Electronic Speed Maintenance	Yes
Collet	1/2" & 1/4" (EU: 12mm)
Depth Adjustment	1. Micro Winder 2. Conventional 'Free' Plunge
Plunge Range	0 - 59mm / 0 - 2 5/16"
Dust Extraction	Yes
Bit Changes	Through-Base, Single Wrench Action, Auto Shaft Lock
Micro Adjustment	Infinite
Spindle Lock	Auto
Safety Power Switch	Yes
Weight	3.9kg

Included Accessories

Table Height Winder handle & Multi-Function Fence

Item	Part No.	Description
804899	TRI-JOF001	Compact Precision Plunge Router 1010W
803129	TRI-TGA250	12 pce Router Accessory Kit

Disclaimer: Every effort has been made to publish the correct details in this brochure. No responsibility will be taken for errors, omissions or changes in product specifications.

Powerful Cutting

Precision cutting performance directed by simple-to-use adjustments ensures total accuracy from Triton saws. Though lightweight and comfortable to use, the rigid framing controls the power output to deliver clean, laser-straight cuts every time.



Precision Power Saw 235mm

TSA 001 235mm / 9¼"

Engineered to provide maximum accuracy for table mounting and hand-held use, this feature-packed, high-performance circular saw delivers power and precision for all cutting requirements.

Maximum rigidity is achieved with the strong, aluminium die-cast base, which has alignment cam location holes for easy fitting and fine tuning in Triton Saw Tables.

Smooth cutting is easily achieved with the needle and ball-bearing constructed 2000W / 3hp motor which, combined with micro angle and blade height adjustment, gives accurate and professional results every time.

The spindle lock and handy on-board spanner assist with quick and easy blade changes. The quick action bevel stops, with a highly accurate calibration scale, are convenient and provide precise settings.



For hand-held or table mounted use in Series 20000 Workcentre

Technical Specification	
Power	2000W (3 hp)
No Load Speed	4100rpm
Blade	235mm
Blade Arbor	16 or 25mm
Bevel Adjustment	0 - 45°
Cutting Depth	0° - 82mm 45° - 58mm
Weight	8kg
Included Accessories	
Rip Fence, 40 TCT blade, Blade Spanner	

Item	Part No.	Description
804887	TRI-TSA001	Circular Saw Precision

Disclaimer: Every effort has been made to publish the correct details in this brochure. No responsibility will be taken for errors, omissions or changes in product specifications.

Precision Power Saw 184mm

TA 184CSL 184mm / 7¼"

Powerful yet lightweight, the TA184CSL hand-held saw features a powerful motor that will take on some of the toughest timbers with plenty of power in reserve.

Accurate and safe to use, the built-in laser line generator produces accurate cuts and increases productivity. Handling is also made easy with the front bail handle, which offers a greater level of control and comfort over the traditional handle design.

Aluminium alloy construction on the upper and lower guards and base ensures greater strength and durability, resulting in a significantly lighter weight tool.

For a clean, safe working environment, the dust port is fitted to the guard for easy connection to a dust extraction system, while the oversized rubber-tipped guard return lever is easy to reach and grip.

1800W / 2½ hp Motor

provides enough power for even the toughest timbers



Dust Extraction Port

for easy connection to a dust collection system

Power Neon-On

increases operator safety

Laser Line Generator

for increased accuracy, safety & maximum productivity

Rubber-Coated Return Lever

for easy access & control of the lower guard

Bevelling to 45°

increases range of adjustment



Easy Access Brushes

enables brushes to be changed quickly & easily

Front Bail Handle

offers greater grip & control at various operating angles



Technical Specification

Power	1800W
No Load Speed	5000rpm
Insulation Class	Double Insulated
Blade Diameter	185mm / 7¼"
Blade Teeth	24 TCT
Bevel Range	1° - 45°
Max Depth of Cut	45° - 39mm / 45° - 1½" 90° - 62mm / 90° - 2½"
Laser	Class: 2, Wave Length: 650nm
Weight	5.1kg / 11.2lbs

Included Accessories

24 TCT Blade, Parallel Guide, Pin Wrench & Hex Key, Dust Extraction Adaptor

Item	Part No.	Description
804888	TRI-TA184CSL	Circular Saw Precision

Precision Power Saw 235mm

TA 235CSL 235mm / 9¼"

Maintaining all the key features of the TSA001 that earned the respect of so many woodworkers, the TA235CSL is host to many new features including aluminium guards and base and laser sighting.

Location holes allow easy and rapid fitment to the bevel, and height micro adjustments enable fine tuning for maximum accuracy. A rack and pinion height adjustment system has also been introduced for fast, accurate adjustments when mounted upside down in the Workcentre.

Laser sighting increases user safety, allows for faster set-up and improved accuracy. The flat motor end cap is a convenient feature, allowing the saw to be rested on the motor during blade change.

Supplied with a premium quality 40-tooth tungsten carbide-tipped (TCT) blade for smooth and accurate cuts, the TA235CSL also comes with a fitted dust extraction port for a cleaner, safer working environment.

Rack & Pinion Height Adjustment

for rapid settings hand-held or when table-mounted

Easy Access Brushes

enables brushes to be changed quickly & easily

Flat Motor End Cap

allows saw to be rested on the motor for convenient blade changing

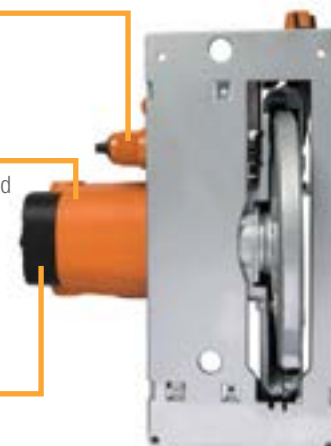

Adjustable Depth Cut

from 0 - 82mm / 0 - 3 15/64" at 90° enables cutting of thick material

Power Neon-On

increases operator safety

Laser Line Generator

for increased accuracy, safety & maximum productivity

Bevel Cuts 0° to 45°

with preset stops at 0°, 15°, 22.5°, 30° & 45° for fast & convenient setting of angle cuts

Micro Depth Adjustment Knob

allows up to 6mm / 1/4" fine tuning

Micro Bevel Adjustment

for fine tuning of the bevel setting



Front Bail Handle

for greater grip & control at various operating angles

Technical Specification

Power	2300W
No Load Speed	4500rpm
Insulation Class	Double Insulated
Blade Diameter	235mm / 9¼"
Blade Teeth	40 TCT
Bevel Range	0 - 45°
Cutting Depth	45° - 60mm / 45° - 2 3/8" 90° - 82mm / 90° - 3 15/64"
Laser	Class: 2, Wave Length: 650nm
Weight	7.7kg / 17lbs

Included Accessories

40 TCT Blade, Parallel Guide, Hex Key, Long Lower Guard Wrench, Long Blade Guard Lever

Item	Part No.	Description
804889	TRI-TA235CSL	Circular Saw Precision

Disclaimer: Every effort has been made to publish the correct details in this brochure. No responsibility will be taken for errors, omissions or changes in product specifications.

Straight Cutting

Precision cutting performance directed by simple-to-use adjustments ensures total accuracy from Triton saws. Though lightweight and comfortable to use, the rigid framing controls the power output to deliver clean, laser-straight cuts every time.

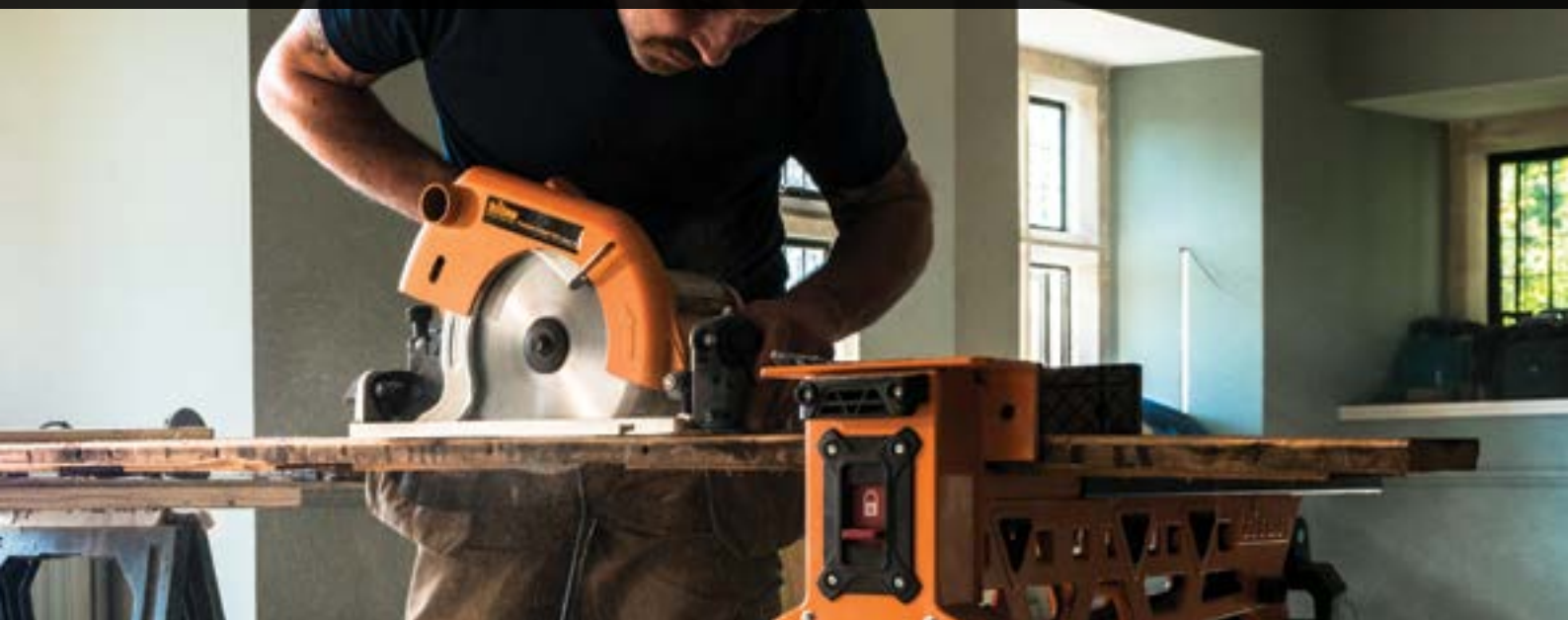

Plunge Track Saw

TTS 1400 165mm / 6½"

The TTS1400 Plunge Track Saw is a highly versatile, feature-packed tool with easy mode selection, fast set-up and advanced safety features.

When fitted to a track, the TTS1400 delivers long, straight cuts, and the flat design of the blade housing means the saw will work right up to the edge of the workpiece – ideal for trimming doors and cutting hardwood flooring.

The mode selector allows quick change between free plunge, scribe or blade change, and cutting width indicators show the exact point at which the blade plunges into the workpiece.

Blade changing is safe and easy. The power switch locks out during the blade-changing process, and the blade is easily accessed through the blade guard without having to remove the cover.

For straight, clean, accurate cuts through any type of wood, Triton's TTS1400 Plunge Track Saw delivers a professional result every time.



Item	Part No.	Description
804906	TRI-TTS1400	Plunge Track Saw

Optional Accessories		
801526	TRI-TTSTP	Track Pack



Blade Change Mode

& power switch lock-out for easy blade changes

Fast Blade Replacement

easily accessed through the blade guard

Precision Bevel Cut

angle adjustment from 0 - 48°

Width of Cut Indicators

for exact positioning of blade on the workpiece

Dual Bevel Quadrants

provide stability for precision cutting



Work Clamps (TRI-TTSCW)



1500mm Track (TTST1500)
(Track supplied seperately)

Optional Accessories		
801519	TRI-TTS60T	Plunge track saw bladed 60T
801526	TRI-TTSTP	Track pack & 2 x 700m connectors
801525	TRI-TTST1500	1500mm track
801524	TRI-TTSSB	Plunge track saw bag
801520	TRI-TTSAS700	Adhesive strip
801522	TRI-TTSCB700	700mm Canvas track bag
801521	TRI-TTSCB1500	1500mm Canvas track bag
801527	TRI-TTSCW	Work clamps

Technical Specification

Power	1400W
No Load Speed	2000 - 5300rpm
Blade Diameter	165mm / 6½"
Bore Diameter	20mm / ¾"
Bevel Range	0 - 48°
Blade Type	60 TCT
Depth of Cut at 90° with Track	54mm / 2¼"
Depth of Cut at 90° without Track	59mm / 2⅝"
Depth of Cut at 45° with Track	38mm / 1½"
Depth of Cut at 45° without Track	42mm / 1⅝"
Weight	5.5kg / 12lbs

Included Accessories

60 TCT Saw Blade, Dust outlet Adaptor, Carbon Brush (Pair)



Unbeatable Sanding

A Triton Sander is a sound investment for controlled, rapid material removal. The refined feature set includes highly effective dust extraction and natural rubber grips for comfort and control over extended periods. Whatever material you are working with, the Triton sanding range has the power to deliver a smooth finish every time.



Palm Belt Sander

TCM BS 64mm / 2½"

Slim and lightweight with a powerful 450W / 3.5A motor, the TCMBS Palm Sander is designed for single-handed use on most wood surfaces.

Delivering ample power for a high rate of stock removal across a broad range of materials, the flush side allows sanding up to the edge of the work-piece.

For confined areas or intricate projects, the small diameter front roller allows sanding in tight, awkward spaces.

Fitted with a comfortable, over-moulded grip and dust extraction port for safe, clean working, the Triton Palm Sander is designed for on-the-spot convenience and makes light work of most common sanding applications.

- Quick-release belt lever
- Sands to edge of workpiece
- Rubber over-moulded grip
- Small diameter front roller
- Belt tracking adjustment

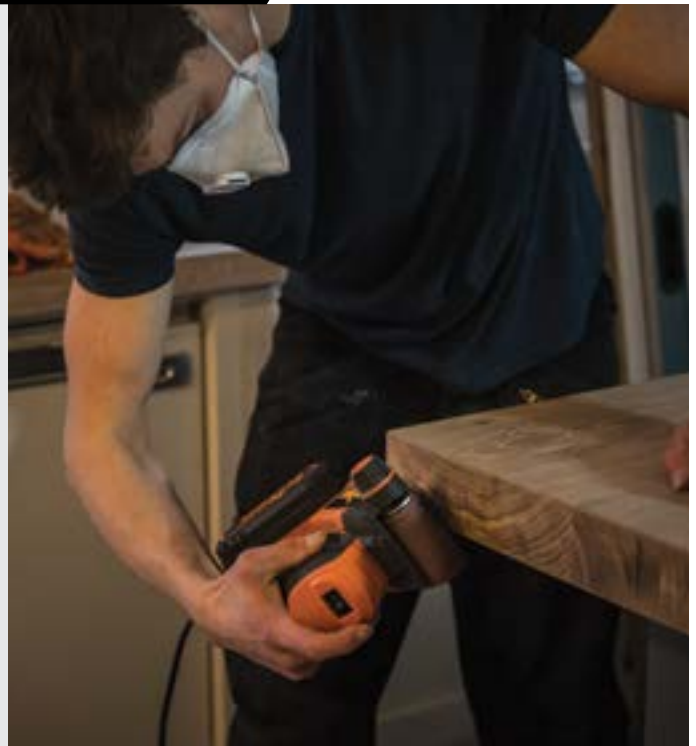

Item	Part No.	Description
804897	TRI-TCMBS	Palm Sander 64mm 450w
803570	TRI-TCMBSB-040	64 x 406 60 Grit
803571	TRI-TCMBSB-080	64 x 406 80 Grit
803572	TRI-TCMBSB-120	64 x 406 120 Grit

Technical Specification	
Power	450W
No Load Speed	340m/min
Belt Size	64 x 406mm
Weight	2.1kg
Included Accessories	
3 x Sanding Belts 60 grit (1 fitted), Dust Extraction Adapter	

Disclaimer: Every effort has been made to publish the correct details in this brochure. No responsibility will be taken for errors, omissions or changes in product specifications.

Belt Sander

TA 1200BS 76mm / 3"

Triton's TA1200BS Belt Sander is host to many significant features, from variable speed control for improved versatility, to belt tracking adjustment for accurate alignment of the sanding belt.

Fitted with a small diameter front roller ideal for sanding in awkward areas, the TA1200BS boasts a rubber over-moulded grip and removable bail handle for increased support, safety and control of the tool.

A powerful, variable speed motor drives the sanding belt at between 200 and 450m/min, complemented by the lock on button which provides convenience and comfort during extended use.

For a cleaner, safer working environment the TA1200BS is fitted with a side dust port that connects to the dust bag supplied with the machine, or can be connected to a dust extraction system.

- Powerful 1200W motor provides power for the toughest wood surfaces
- Variable speed control improves versatility
- Small diameter front roller allows sanding in confined areas
- Adjustable bail handle increases support & safety

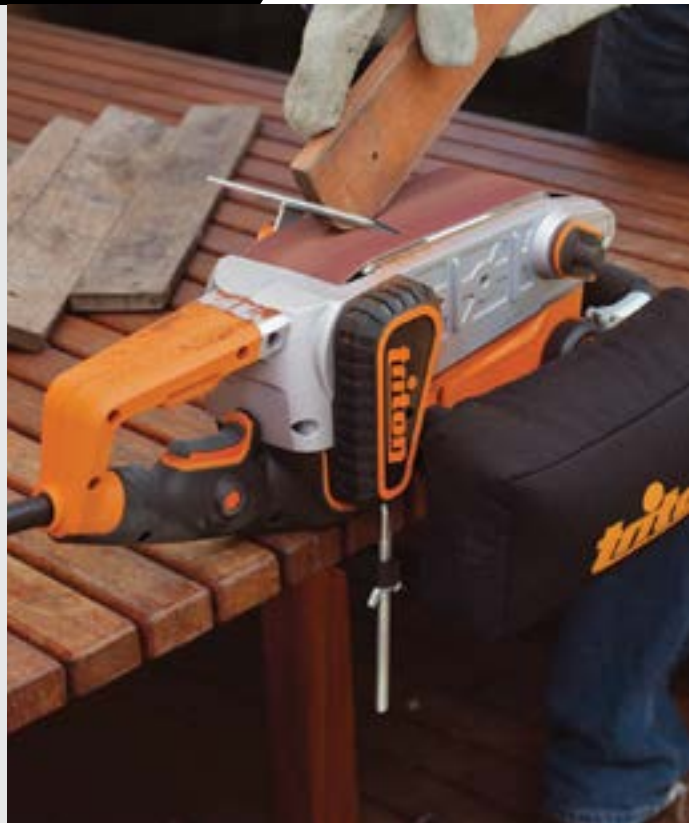

Variable Speed Control

improves versatility when working with different workpieces

Rubber Over-Moulded Grip

offers increased support, safety & control of the tool

Small Diameter Front Roller

for sanding in confined areas of detailed work

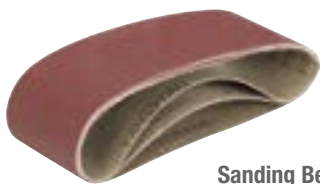

Sanding Belts

Item	Part No.	Description
804893	TRI-TA1200BS	Belt Sander 76mm 1200w
804920	TRI-TBSIS	Sanding Frame to suit TRI-TA1200BS
804916	TRI-TAS60	Belts Sanding 76 x 533mm 60 Grit 5pk
804917	TRI-TAS80	Belts Sanding 76 x 533mm 80 Grit 5pk
804918	TRI-TAS120	Belts Sanding 76 x 533mm 120 Grit 5pk
804919	TRI-TAS180	Belts Sanding 76 x 533mm 180 Grit 5pk

Technical Specification

Power	1200W
No Load Speed	200 - 450m/min
Belt Size	76 x 533mm
Actual Sanding Area	76 x 150mm
Variable Speed	Yes
Gear Casing	Aluminum
Weight	4.8kg

Included Accessories

Dust Bag, Sanding Belt & Inversion Clamps

Geared Eccentric **Orbital Sander**

T GEOS 150mm / 6"

Equipped with a powerful 500W motor, the Triton Eccentric Orbital Dual-Mode Sander tackles the most demanding sanding and polishing tasks with ease. Variable speed control enables the tool to be used with nearly all kinds of materials, and electronic speed maintenance holds the sanding speed constant under load, giving professional results.

Features include a 150mm / 6" diameter hook-and-loop backing pad and two sanding modes. Free-run mode delivers fine, uniform sanding results with slow material removal, while forced orbit rotation mode is used for rapid material removal.

Dust is easily controlled with the highly effective vacuum dust extraction port, and the auxiliary front handle is equipped with a quick-release lever. The handles feature vibration-reducing, rubber overmoulded grips, for maximum protection and comfort.

Includes soft carrying case and various grit sanding discs, so the TGEOS can be used straight out of the box. A pair of spare carbon motor brushes is also included, providing this innovative machine with a long service life.

Rubber Over-Moulded Grip

provides comfort & grip for extended use



Free-Run Mode:

Fine sanding with low material removal

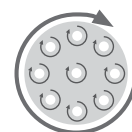

Fixed Orbit Mode:

Course sanding with high material removal & buffing

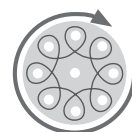

Electronic Speed Maintenance Under Load

ensures maximum control at all times

Variable Speed Control & Backing Pad Braking System

adapt to a variety of materials & prevent workpiece damage

Adjustable Auxiliary Handle

adapts the tool to the job & matches operator preference



Dual-Orbit Sanding Action

with free-run mode for fine sanding & geared fixed orbit mode for fast material removal & buffing

Vacuum Dust Extraction Port

for increased operator safety & clean work areas

Powerful 500W Motor

provides ample power for the most demanding sanding & polishing tasks



Technical Specification

Power	500W / 4.5A
No Load Speed	2500 - 6250rpm
PlatePad Diameter	150mm / 6"
Orbit Eccentricity	5mm / 3/8" Random or Forced
Adjustable Bail Handle	Rotating & Swivel
Sanding Disc	Hook & Loop
Power On Neon	Yes
Sanding Modes	Dual (Random & Fixed Orbit)
Weight	3.1kg / 6.8lbs

Included Accessories

Soft Carry Case, 6 x Sanding Discs & 1 x Spare Carbon Brushes

Item	Part No.	Description
804904	TRI-TGEOS	Orbital Sander

Accurate Jointing

Dowel jointing provides a swift and secure solution for simple joints. A Triton jointer can effortlessly reproduce consistently accurate joints in a variety of materials. Calibrated rules and an innovative rack and pinion movement help maintain precision, allowing you to dial in the required angle and depth for simultaneous, synchronised pockets.



Duo Dowel Jointer

TDJ 600 710W

Offering precise control of height, depth and angles, the TDJ600 Duo Dowel Jointer drills two holes at 32mm centres in a single action.

Quick, accurate adjustment of material thickness is easy with the rack and pinion mechanism, whilst the clear, calibrated viewer enables precise set-up and execution.

Ideal for forming strong, reliable, edge-to-edge and mitre corner joints, the Duo Dowel Jointer creates accurately spaced joints along the length of the workpiece.

Anti-slip pads help prevent movement during the drilling process to ensure fast, reliable jointing.

Motor housing can be easily removed to replace worn carbon brushes and dust port allows connection to an extraction system for a clean, safe working environment.



Precision Rack & Pinion System

allows accurate adjustment for material thickness

Front Bail Handle

increases control & grip



On / Off Switch

positioned for easy access

Dust Port

allows connection to extraction system for a cleaner & safer working environment

Variable Setting for Drill Depth

meets precise requirements of each joint

Item	Part No.	Description
804898	TRI-TDJ600	Duo Dowel Jointer 710W
804926	TRI-TDJDB	Dowel Jointer Bits 8mm
803496	TRI-TDJDB	Dowel Jointer Bits 10mm

Technical Specification

Power	710W / 5A
No Load Speed	17,000rpm
Drilling Height	9 - 43mm / 3/8" - 1 1/16"
Drilling Depth	0 - 38mm / 0 - 1 1/2"
Drill Bit Spacing	32mm / 1 1/8"
Weight	2.8kg / 6.1lbs

Included Accessories

2 x 8mm / 3/8" dia drill bits,
Dust Port Adaptor, Hex Key

Disclaimer: Every effort has been made to publish the correct details in this brochure. No responsibility will be taken for errors, omissions or changes in product specifications.



Innovative Planing

Patented triple-blade planing technology is a unique feature of the Triton range. The additional cuts achieved with each revolution greatly improve the finish and reduce long-term wear on the tool. Other innovations, such as positioning the motor above the blade, greatly improve the air flow, allowing high volumes of shavings to be ejected cleanly. Calibrated depth control and ridged guide fences ensure total accuracy and precise finishing.

Compact Palm Planer

TCM PL 420W

The TCMPL Compact Palm Planer is powerful, easy to handle, and includes all the features of a conventional-sized planer and more.

Utilising twin 60mm solid TCT blades, the TCMPL offers the perfect combination of power and balance with excellent grip for safe, one-handed operation.

The 420W / 3.5A motor and 60mm planing width make this planer ideal for fast material removal on small to medium-sized workpieces.

Up to 1.5mm of material can be removed in one pass, and the adjustable planing depth with 3 bevelling grooves ensures flatness and improves cutting accuracy.

A power lock-off switch prevents accidental operation, and the foldaway blade protection foot prevents damage to the blades when the planer is resting on a surface.



Slim Handle Design

is easy to hold & control using one hand

Rubber Over-Moulded Grip

increases control & safety



Stepped Depth Control

allows accurate cutting depth from 0-1.5mm / 0 - 1/16"

Parking Stand

protects the blades & workpiece from damage on run down



Technical Specification

Power	420W / 3.5A
No Load Speed	13,000rpm
Planing Depth	1.5mm / 1/16"
Planing Width	60mm / 2 3/8"
Blade Type	2 x Reversible 60mm HSS / 2 x Reversible 2 3/8" HSS
Weight	2.4kg / 5.3lbs

Optional Accessories

TCMPLB60	60mm / 2 3/8" Planer Blades x 2
----------	------------------------------------

Item	Part No.	Description
802734	TRI-TCMPL	Compact Palm Planer
803567	TRI-TCMPLB60	60mm Planer Blades, Pkt of 2

Disclaimer: Every effort has been made to publish the correct details in this brochure. No responsibility will be taken for errors, omissions or changes in product specifications.

Unlimited Rebate Planer

TRP UL 82mm 750W

The TRPUL's patented triple-blade drum delivers an impressive 46,500 cuts per minute for fast material removal and a superior finish to every project.

Traditionally the rebate depth for any planer is restricted by body design, however the TRPUL is designed with the blade drum positioned to the outermost edge, allowing unrestricted depth rebates right to the edge of the workpiece.

In addition, the removable blade drum system allows fitment of the sanding drum (both included) to convert the planer into a highly efficient sander.

With the high mount position of the motor improving airflow, chip extraction is maximised via the selectable left or right rear dust extraction, ensuring sawdust is directed away from the operator and workpiece at all times.

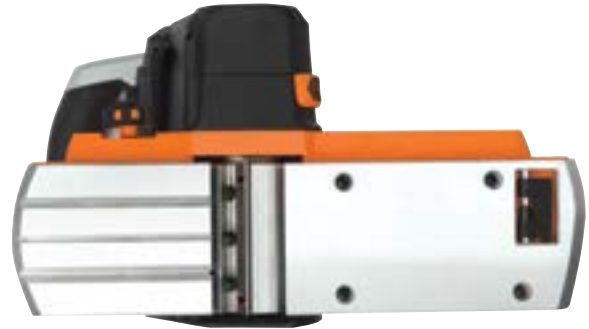

Left or Right Rear Dust Extraction

allows the dust/chips to be directed either side of the workpiece

Power-On Neon

increases operator safety

Variable Speed Control

adjusts the drum speed to suit the material



Spindle Lock Button

for easy drum changes

Patented 3-Blade Drum

provides a higher rate of material removal (46,500 cuts per minute)

Parking Stand

protects the blades & workpiece from damage on run-down



Item	Part No.	Description
804894	TRI-TRPUL	Unlimited Rebate Planer
803566	TRI-TRPPB	HSS Planer Blades Pkt 3 to suit TRI-PUL
804921	TRI-TRPSS	Sleeve sanding 80g to suit TRI-PUL



Technical Specification

Power	750W / 6.5A
Variable Speed	5000 - 15,500rpm
Cuts Per Minute	46,500
Planing Depth	0 - 3mm / 1/8"
Planing Width	82mm / 3 1/4"
Blade Type	3 x Reversible HSS
Weight	2.4kg / 5.3lbs

Included Accessories

Sanding Drum with Sanding Sleeve, Planing Drum (HSS 3 Blade), Wrench and Hex Spanner, Dust Bag and Adaptor, Guide Fence

Triple Blade Power Planer

TPL 180 180mm / 7"

The TPL180 Triple Blade Power Planer features a huge 180mm / 7" width for heavy duty planing of the toughest wood surfaces.

Packing twice the power of conventional planers, the 1500W / 12.5A motor delivers precise material removal and a superior finish.

The revolutionary 3-blade drum delivers a massive 45,000 cuts-per-minute, improving balance, reducing vibration and blade wear, increasing the speed of cut, and producing a smoother finish.

A low centre of gravity design means this large, powerful machine is easy to control, whether on wide or narrow planing surface areas, and the dust extraction port easily connects to a dust extraction system for a cleaner, safer, working environment.



Power-On Neon

indicates a live power connection

Dust Port

for connection to a dust extraction system

Powerful 1500W Motor

for heavy duty planing of the toughest wood surfaces



Revolutionary 3-Blade Drum Design

for faster, smoother cuts & a superior finish

Includes Parking & Calibration Settings

0 - 2mm / 0-3/32" cut depth plus parking setting



Item	Part No.	Description
804892	TRI-TPL180	Triple Blade Planer
803561	TRI-TPL180PB	180mm planer blades, Pkt of 3 to suit TRI-TPL180

Technical Specification

Power	1500W / 12.5A
No Load Speed	15,000rpm
Cuts Per Minute	45,000
Planing Depth	0 - 2mm / 3/32"
Planing Width	180mm / 7"
Blade Type	3 x Reversible 180mm / 7" 65Mn
Weight	8.2kg / 18.7lbs

Included Accessories

Wrench, Dust Bag, Dust Connector, Guide Fence, 3 x Reversible 65Mn blades

Bench Top

In the workshop or on site, Triton Bench Top tools extend your woodworking capabilities. Projects get off to a better start with super-smooth stock, and a higher standard of finish is achieved when stock is cut precisely with a razor-sharp edge. Solidly constructed, with a wealth of accessories to extend functionality, you can expect years of reliable service from Triton's Bench Top tools range.



Planer / Thicknesser

TPT 125 317mm / 12½"

Offering the full 317mm cutting width, the TPT125 Planer / Thicknesser delivers 17,500 cuts per minute for a high quality, consistently smooth finish to the workpiece.

Large infeed and outfeed tables provide added material support for long workpieces and a capacity for timber from 3.2mm up to 152mm depth.

A circuit breaker ensures enhanced electrical safety and the dust chute, which can be mounted on either end of the thicknesser, provides a cleaner, safer, working environment.

Precise setting of the cutting depth is easy with the graduated depth crank handle and clear, easy-to-read thickness scale. The 4-post column design provides rigidity and allows the cutter head to be raised and lowered smoothly and accurately for precise results.

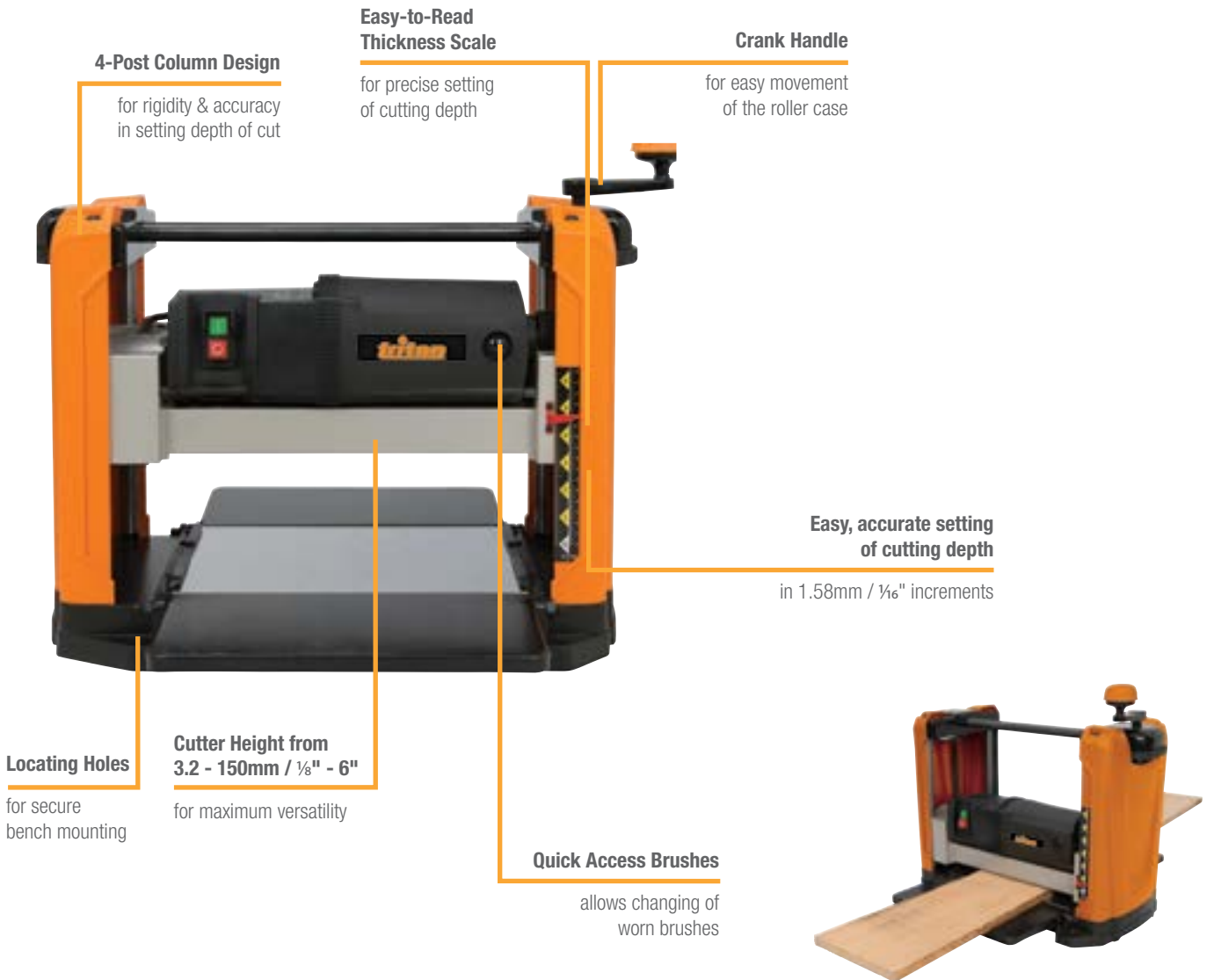

Item	Part No.	Description
804886	TRI-TPT125	Planer/Thicknesser
803560	TRI-TPTPB	Spare blade planer thicknesser HSS 317mm reversible 2pkt

Technical Specification	
Power	1100W / 1½hp
Cuts Per Min	17,500cpm
Planing Depth	3.2 - 152mm / 1/8" - 6"
Planing Width	317mm / 12 ½"
Table Size	317 x 320mm / 12½" x 12 39/64"
Weight	29kg / 64lbs

Disclaimer: Every effort has been made to publish the correct details in this brochure. No responsibility will be taken for errors, omissions or changes in product specifications.

Oscillating Spindle Sander

TSPS 450 450W

Triton's Oscillating Spindle Sander offers outstanding performance and a precise finish to every wood working project.

Stability and enhanced material support for larger stock is provided by the cast iron table. The oscillating action moves the drum up and down during rotation, reducing the static friction that causes burning, and eliminating band marks. It also extends the life of the sanding sleeve by spreading the wear across a broader surface.

Supplied with six sanding sleeves with matching rubber drums and table inserts, the Triton Oscillating Spindle Sander is well equipped to provide a professional finish to internal as well as external profiles. This also allows the matching of the optimum size of sleeve for the precise needs of each woodworking project.



Large Cast Iron Table

for stability & enhanced material support

Rotating & Oscillating Action

for precise finishing of intricate work



Dust Port for connection to an extraction system



Power Switch with Dust Cover

for ease of use & long, trouble-free performance

On-Board Storage

keeps all accessories neatly to hand



Sanding Sleeves

- Sizes 13, 19, 26, 38, 51 & 76mm
- Length 115mm
- Aluminium oxide



Item	Part No.	Description
804895	TRI-TSPS450	Oscillating Spindle Sander 450W
801502	TRI-TSS60G	6pc Sleeves 60 Grit
801503	TRI-TSS80G	6pc Sleeves 80 Grit
801499	TRI-TSS100G	6pc Sleeves 100 Grit
801500	TRI-TSS150G	6pc Sleeves 150 Grit
801501	TRI-TSS240G	6pc Sleeves 240 Grit



Technical Specification

Power	450W
No Load Speed	2000rpm
Oscillations	580pm
Table Size	370 x 295mm
Dust Port	38mm
Weight	12.9kg

Included Accessories

6 x Aluminium Oxide Sanding Sleeves from 13 - 76mm, 6 x Table Inserts, 5 Rubber Sanding Drums, 3 x Upper Spindle Washers & 1 x Wrench

Wetstone Sharpener

TWS S10 120W

Fitted with a pre-dressed, high-grade grindstone and leather honing wheel, the Triton Wetstone Sharpener produces a polished, razor-sharp edge on cutting and shaping tools.

Used in conjunction with the supplied honing compound, the leather honing wheel delivers a finely polished finish, ideal for hand tools, knives, plane irons, chisels and other wood carving tools.

Edges won't overheat or lose their sharpness due to the water-cooled, slow speed of the wetstone sharpener. Using the support arm, angle guide and jig, it is easy to shape and sharpen a blade precisely to the angle required.

Pre-dressed and ready for use, the high-grade diamond grindstone can be easily and quickly re-dressed with the provided stone grader. The 120W induction motor provides long-lasting, smooth performance and rubber feet keep the machine steady and minimise vibration for a perfect finish.



Item	Part No.	Description
804891	TRI-TWSS10	Wetstone Sharpener

Disclaimer: Every effort has been made to publish the correct details in this brochure. No responsibility will be taken for errors, omissions or changes in product specifications.

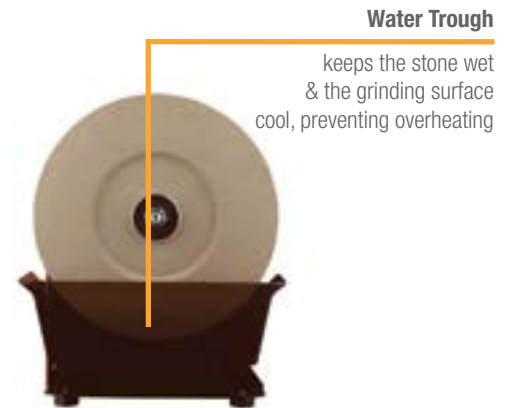

Technical Specification

Power	120W / 1A
No Load Speed	2800rpm
Wheel Speed	125rpm
Bore Diameter	Ø 12mm / Ø 1/2"
Sharpening Stone Size	Ø 250 x 50mm 220 Grit / 10" x 2" 220 Grit
Honing Wheel	Ø 230 x 30mm / 9 x 1 1/16"
Weight	14.5kg / 29lbs

Wetstone Sharpener **Optional Accessories**

TWS S10

Expand the functionality of the Wetstone Sharpener with a choice of products for honing, sharpening and polishing virtually every kind of cutting tool.

Precisely designed and engineered specifically for use with the Wetstone Sharpener, the range also includes accessories to keep the sharpener in peak condition for a quality performance on every project.



TWS TR

804698

Tool Rest

For sharpening an assortment of tools, especially tools requiring larger bevel angles. Provides stable platform.

TWS LKJ

804691

Long Knife Jig

For long or thin flexible filleting knives. The broad clamping head holds blades securely.



TWS DTT

804699

Diamond Truing Tool

Quick restoration of the grinding surface. The back bar controls rate of material removal.



TWS SG

804692

Stone Grader

For dressing the grinding stone. Course 220 Grit Fine 1000 Grit



TWS TGJ

804700

Turning Gouge Jig

For controlled, accurate sharpening of woodturning tools.



TWS GAJ

804693

Grinding Angle Set-Up Jig

For setting up the correct angle for sharpening. Enables repeated accurate grinding of specific bevel angles.



TWS PCJ

804701

Plane Camber Jig

Puts an even, slight radius onto a hand plane iron, especially good for scrub and jack plane irons. Camber for improved shearing action.



TWS SJ

804694

Scissors Jig

Restores sharp edges to blunt scissors and garden shears. Twin clamps for securing blades.



TWS SEJ

804702

Straight Edge Jig

Maintains correct sharpening angle. Easy, accurate tool fitting.



TWS SAE

804695

Support Arm Extension

Attaches to support arm. Provides simultaneous tool support above the grindstone and honing wheels.



TWS DW

804703

Pre-Dressed Coated Grindstone

High-grade grindstone that sharpens steel edges efficiently and reliably.



TWS CTJ

804696

Carving Tool Jig

For accurate sharpening of carving tools and other short tools. Clamps narrow and butt chisels firmly. Internal "V" shape automatically centres the tool.



TWS WSC

804704

Machine Cover

Keeps dust and dirt off the Wetstone Sharpener when not in use.



TWS LHW

804697

Profiled Leather Honing Wheel

For honing and polishing the inside of turning and woodcarving gouges. Honing/polishing V-parting tools. Made from solid tanned leather.



TWS MP

805000

Metal Polish

For dressing the leather honing wheel.



Work Support

Whenever you need an extra pair of hands - from supporting timber for cutting logs, clamping a door for trimming, storage of timber stock, or protecting your tools and materials for transport - Triton Work Support products have the solution.



SuperJaws Clamping System

SJA 200

The iconic SuperJaws can be easily transported right to the job, whether indoors, outdoors or the workshop floor.

SuperJaws provides fast, hands-free clamping of material up to 956mm, and a massive clamping force of up to 1000kg.

Constructed from tough, powder-coated steel, SuperJaws will hold anything - from car parts and bicycles to timber and tubing.

Features include a lock / release switch for fast release of the workpiece, and reversible jaws for extra-wide clamping capacity.

Technical Specification

Clamping Range	0 - 956mm / 0 - 37 4/64"
Clamping Force	Up to 1000kg / 2200lbs
Clamping Method	Foot Operated
Standard Jaws	Urethane
Max Load	100kg / 220lbs
Folded Size	745 x 278 x 300mm / 29 23/64" x 10 15/16" x 11 13/16"
Standing Size	970 x 960 x 860mm / 38 3/8" x 37 5/64" x 33 5/64"
Weight	15kg / 33lbs

Included Accessories

Rip Fence, 40 TCT blade, Blade Spanner



Finishing



Wood Working

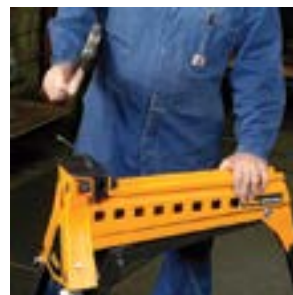

Engineering



Log Cutting

Item	Part No.	Description
801269	TRI-SJA200	SuperJaws MK2

Disclaimer: Every effort has been made to publish the correct details in this brochure. No responsibility will be taken for errors, omissions or changes in product specifications.

SUPERJAWS



Quickly Folds Down for storage and transport



Urethane Jaw Facings

provide a protective, slip-resistant grip



Robust, All-Steel Construction

with powder coat finish for long-lasting operations

Lock / Release Switch

allows fast, trouble-free release of the jaws



Extra-Wide Tripod Base

for all-terrain stability

Foot operated hands-free clamping up to 1000Kg

frees up your hands for full control of the job



956mm

SOLID STEEL

100kg
220lbs

1 TONNE CLAMPING FORCE

Accessories

Log Jaws

- Strong jaws for working on logs & poles up to approx 300mm dia
- Ideal for chainsawing, drilling, fastening or carving work
- Serrated teeth prevent slippage or rolling
- Fits easily on SuperJaws in place of the standard urethane jaws
- Steel plate & zinc-plated for corrosion resistance
- Compatible with all Superjaws



Engineers Jaws

- Shaped for increased grip on metal bars, tubes and piping up to 50mm dia.
- Tough cast iron jaws & anvil face for heavy duty metal work
- Easy to fit & remove
- Compatible with all SuperJaws



Tool Tray / Work Support

- Provides extra support for large work-pieces
- Keeps tools, spare parts or other items conveniently to hand
- Robust & hardwearing
- Easy to fit & remove
- Compatible with Superjaws SJA200



Item	Part No.	Description
801321	TRI-SJA460	Log And Pole Gripping Jaws

Item	Part No.	Description
801322	TRI-SJA470	Cast Engineers Jaws

Item	Part No.	Description
801320	TRI-SJA420	Tooltray Comb Side Support

Multi-Stand

MSA 200

Multi-purpose, adjustable support stand with extra-wide tripod base for excellent stability on level or uneven ground. Folds down in seconds for convenient transportation and storage. Swivelling and tilting head with built-in clamp and low-friction slide surfaces.

- Swivelling & tilting head with built-in clamp & low-friction slide surfaces
- Secures work at almost any angle & supports up to 100kg
- Height adjusts from 635 - 940mm
- Extra-wide tripod base for stability
- Folds flat for easy storage



Angle Adjustment Head

with built-in clamping system

Low Friction Slide Surfaces

provides smooth controlled travel without unwanted 'steering'

Head Pivots

from horizontal to vertical

Height Adjusts

from 635 - 940mm / 25 - 37"

Extra-Wide Tripod

for excellent stability on level or uneven ground

Item	Part No.	Description
804907	TRI-MSA200	Multi Stand

Technical Specification

Max. Load	100kg / 220lbs
Height Range	635 - 940mm / 25" - 37"
Tilt Adjustment	Vertical Through Horizontal
Weight	6.2kg / 13.6lbs

Disclaimer: Every effort has been made to publish the correct details in this brochure. No responsibility will be taken for errors, omissions or changes in product specifications.

Woodrack Storage System

WRA 001

Triton WoodRack is easy to install, providing generous storage for wood, piping, guttering and long metal pieces on six levels, each with a capacity of 50kg.

- Provides generous storage for timber, pipes etc.
- For internal or external use
- Ideal for workshops, garages, sheds, fences, walls etc.
- 12 supports provide 6 levels of storage - 50kg per level
- Robust powder-coated steel tubing



Generous Storage Capacity
for timber, pipes & other long items

6 Levels
for storage of all materials

Made from 30mm Steel Tubing
& powder coated for increased durability & life

Holds 50kg / 110lbs
of material per level

Technical Specification

Max. Load	Holds 50kg / 110lbs of Material Per Level
Depth	300mm / 12"
Height	1040mm / 41"
Tube Size (upright)	25 x 1.6mm in Mild Steel / 1 in/sq x 1/8" in Mild Steel
Tube Size (racks)	30 x 1.6mm in Mild Steel / 3/16 in/sq x 1/8" in Mild Steel
Weight	7.8kg / 17lbs

Included Accessories

12 x Racks, 12 x End Caps, 12 x 6g x 1/4" Pan Head Screws, 2 x Uprights, 6 x Spacers

Item	Part No.	Description
801573	TRI-WRA001	Woodrack Storage System

Precision Router Table System - Series 2000

RTA 300

Quick installation of any Triton Router is easy with the Precision Router Table System. Featuring slots on the mounting plates and including quality, heavy duty fittings, almost any ¼" or ½" Router can be installed.

By adding other accessories, the system will perform jigsaw cutting, biscuit jointing and finger jointing.

Fitting the Triton Router Table (RTA300) to the Triton Workcentre or Router Stand adds a whole new dimension to woodworking, allowing shaping, planing, rebating, trenching, moulding and grooving.

Whatever the job, the Triton Router Table offers remarkable accuracy, exceptional versatility and enhanced safety for professional results.



Double-Sided Protractor

fitted with grip tape for added non-slip support with 90° range

Small & Large Cutter Inserts

provide maximum support for the workpiece

Non-Return Pressure Fingers

for fully adjustable vertical & horizontal support

Steel Frame Fence with MDF Face

is easily replace when worn or damaged

Micro Adjusters

for fine adjustment of the fence position for rebating & planing

Powder-Coated Table

ensures a sturdy flat surface with quick-fit system

Dust Extraction Tube

for connection to a dust extraction system



Technical Specification

Table Size	540 x 690mm / 21 x 27"
Cuts	Planing, Trenching, Rebating, Moulding, Endgrain Work, Free-hand work
Bevel Adjustment	90°
Dust Extraction	Yes
Weight	11kg / 24lbs

Included Accessories

Planing shims, alignment tool & cutter inserts

Item	Part No.	Description
801245	TRI-RTA300	Router Table



Safe free-hand operation when safety guard is fitted on its own to the table top.

Router Not Included



Router Table shown mounted on Triton Workcentre.

Router Not Included



Steel frame fence with MDF face. Faces are easily replaced when worn.

Router Not Included

Router Table - Series 2000

RSA 300

Purpose-designed support stand for use with the Triton Router Table. Features include adjustable leg height for stability on uneven ground, and on / off switch with quick-stop panel for added safety. The stand also folds down for convenient transportation and storage.

- Safety on/off switch
- Adjustable leg height
- Onboard leg storage
- Folds down for easy transportation
- Compatible with all Triton Router Tables



Onboard Leg Storage

for easy portability & compact storage

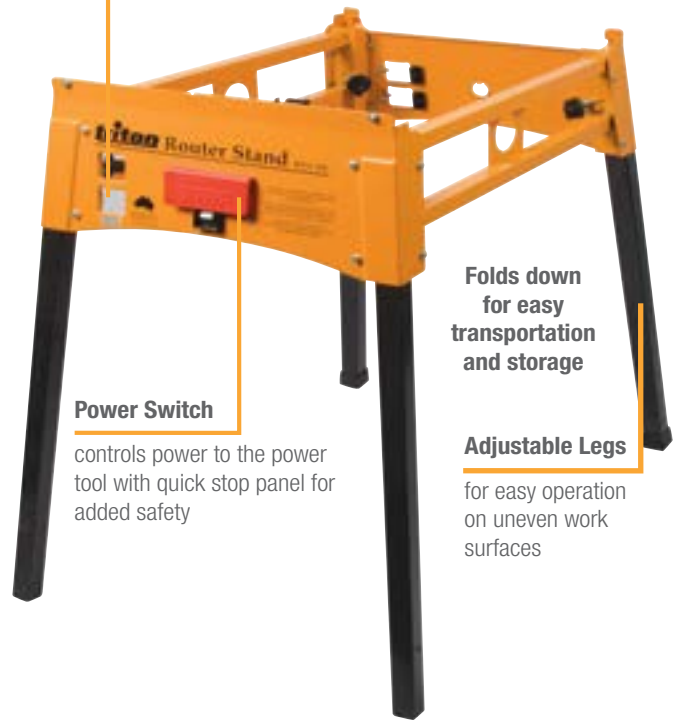

Power Switch

controls power to the power tool with quick stop panel for added safety

Folds down for easy transportation and storage

Adjustable Legs

for easy operation on uneven work surfaces

Item	Part No.	Description
801241	TRI-RSA300	Triton Router Stand

Technical Specification	
Table Size	650 x 690mm / 25 x 27"
Weight	11.4kg / 25lbs

Router Table Accessories - Series 2000

Finger Jointer

- Creates strong, accurate 1/4" & 1/2" decorative box joints ... 1/2" cutter included
- Suitable for 3 - 32mm board thickness
- Cuts several joints simultaneously
- Dust extraction port
- Compatible with Triton Router Table RTA300



Item	Part No.	Description
801216	TRI-FJA300	Finger Jointer

Biscuit Joiner

- Ideal for bevel, mitre & edge joinery
- Quick & easy to fit
- Fast, strong & invisible jointing of timber sections
- Includes TCT cutter & pack of biscuits
- Compatible with 1/4" & 1/2" routers
- Compatible with Router Table RTA300



Item	Part No.	Description
801191	TRI-BJA300	Biscuit Joiner
801189	TRI-BJA050	Biscuits, Pack of 50
801190	TRI-BJA056	Biscuits, Pack of 500

Workcentre Accessories - Series 2000

Overhead Mounting Kit

- Robust steel construction
- Router slide plate for overhead work
- Suits most routers for cross trenching on Triton Workcentres (except TWX7)
- Offers high accuracy for shelving, cabinets & built-in cupboards



Item	Part No.	Description
801182	TRI-AJA150	Router Mounting Plate

Blade Height Winder Kit

- Quick, precise blade height adjustment:
 - by winder through the table slot
 - by thumb wheel in crosscut mode
- Allows saw to remain at its full depth
- Compatible with Workcentre System Series 2000



Item	Part No.	Description
801563	TRI-WCA390	Height Winder Kit

Workcentre Dust Bag

- Easy-to-fit
- Detachable pouch
- Bayonet & tapered hose connectors
- Vacuum hose
- Fits most Triton Workcentres



Item	Part No.	Description
801209	TRI-DCA250	Workcentre Dust Bag

Planer Attachment Kit

- For perfectly smooth, straight faces
- Includes detachable dust collection bag
- Quick, fold-away action for fast changes between planer & saw modes
- Adjustable pressure fingers
- Separate switch box with safety shut-off
- Suits most 82mm electric planers



Power Tool NOT included

Item	Part No.	Description
801211	TRI-EPA001	Planer Attachment Kit

Bevel Ripping Guide

- Enables accurate bevels & chamfers from 15 - 90°
- Integral calibration for easy alignment
- Fully adjustable to handle long & wide workpieces
- Compatible with Triton Workcentre System 2000



Item	Part No.	Description
801194	TRI-BRA200	Bevel Ripping Guide

Mini Sliding Extension Table

- Crosscut capacity up to 600mm, rip capacity up to 1000mm
- Compatible with Triton Workcentres (except TWX7), Saw Tables and Router Stand RSA300
- Easy-to-read calibration scales
- Multi-position fence
- Folds for storage



Item	Part No.	Description
801214	TRI-ETA100	Mini Sliding Extension Table

Maxi Sliding Extension Table

- Cross cut capacity up to 1200mm
- Rip capacity up to 1220mm accommodates 2400 x 1200mm sheets
- Easy-to-read calibration scales
- Table can be locked in position
- Sliding Table acts as panel saw
- Compatible with Triton Workcentres (except TWX7)



Item	Part No.	Description
801215	TRI-ETA300	Maxi Sliding Extension Table

Ask for a woodworking demonstration, available from your Triton Platinum distributor:

P_AUS/NZ_T_TTRITON_BR_2017

WHITE INTERNATIONAL PTY LTD

60 Ashford Ave Milperra NSW 2214
PO Box 304 Milperra NSW 2214
Phone 02 9783 6000 Fax 02 9783 6001
Customer Service 1300 780 876
Email Sales: sales@whiteint.com.au
General Info: info@whiteint.com.au
www.whiteint.com.au

Please always refer to our website for further technical information & new product innovations

Disclaimer: Every effort has been made to publish the correct details in this brochure. No responsibility will be taken for errors, omissions or changes in product specifications. Product images are representations only.

WHITE INTERNATIONAL NZ LTD

15G Kerwyn Avenue
East Tamaki, Auckland 2013, New Zealand
Phone 09 579 9777 Fax 09 579 7775
Customer Service 0800 509 506
Customer Service Fax 0800 804 344
Email Sales: sales@whiteint.co.nz
www.whiteint.co.nz



Scan QR Code on your smart phone or iPad to save a digital version.

